

Factor IX Complex Profilnine®

DESCRIPTION

Profilnine®, Factor IX Complex, is a solvent/detergent treated, nanofiltered, sterile, lyophilized concentrate of coagulation factors IX, II, X, and low levels of factor VII. The factor II content is not more than (NMT) 150 units* per 100 factor IX units, the factor X content is NMT 100 units per 100 factor IX units, and the factor VII content is NMT 35 units per 100 factor IX units. Profilnine does not contain heparin and contains no preservatives. Profilnine contains few, if any, activated factors based on results from the non-activated partial thromboplastin time (NAPTT) test^{1,2}.

Profilnine is intended for intravenous administration only. Each vial is a single-dose container and is labeled with the factor IX potency expressed in International Units.

Profilnine is prepared from pooled human plasma and purified by diethylaminoethyl (DEAE) cellulose adsorption. The risk of transmission of infective agents by Profilnine has been substantially reduced by donor selection procedures and virus screening of individual donations and plasma pools by serological and nucleic acid testing. In addition, virus elimination steps such as nanofiltration³ and solvent/detergent (tri-n-butyl phosphate) treatment⁴ have been incorporated into the Profilnine manufacturing process. Additional removal of some viruses occurs during the DEAE cellulose product purification step.

The ability of the manufacturing process to eliminate virus from Profilnine was evaluated in the laboratory by intentionally adding virus to product just prior to the elimination step and monitoring virus removal. Table 1 shows the amounts of virus that can be removed by solvent/detergent treatment, nanofiltration, and purification by DEAE chromatography when vesicular stomatitis virus (VSV), human immunodeficiency virus-1 and 2 (HIV-1, HIV-2), parvovirus, West Nile virus (WNV), bovine viral diarrhoea virus (BVDV), hepatitis A virus (HAV), and pseudorabies virus (PRV) were evaluated in these virus spiking studies. The results indicate that the solvent/detergent treatment step inactivates enveloped viruses and the nanofiltration step removes both enveloped and non-enveloped viruses.

Table 1: Virus Reduction

Virus	Virus Type	Model For:	Virus Reduction (log ₁₀)		
			Process Step		
			1st DEAE Chromatography	Solvent-Detergent	Nanofiltration
Sindbis	Env	Hepatitis C	1.4	≥ 5.3	NT
VSV	Env	Robust enveloped viruses	NT	≥ 4.9	NT
HIV-1	Env	HIV-1	NT	≥ 12.2	≥ 6.2
HIV-2	Env	HIV-2	NT	≥ 6.0	NT
WNV	Env	WNV	NT	NT	≥ 6.6
BVDV	Env	Hepatitis C	NT	NT	≥ 4.9
Parvo*	Non-Env	Parvovirus B19	NT	NT	≥ 6.1
HAV	Non-Env	HAV	NT	NT	≥ 5.8
PRV	Env	Hepatitis B	NT	NT	≥ 5.3

* Porcine, NT=Not tested, Env=Enveloped

CLINICAL PHARMACOLOGY

Profilnine is a mixture of the vitamin K-dependent clotting factors IX, II, X, and low levels of VII. The administration of Profilnine temporarily increases the plasma levels of factor IX, thus enabling a temporary correction of the factor deficiency.

A clinical study that evaluated twelve subjects with hemophilia B indicated that, following administration of Profilnine, the factor IX in vivo half-life was 24.68 ± 8.29 hours and recovery was 1.15 ± 0.16 units/dL per unit infused per kg body weight.

Administration of Factor IX Complex can result in higher than normal levels of factor II due to the significantly longer half-life of factor II⁵.

INDICATIONS AND USAGE

Profilnine, Factor IX Complex, is indicated for the prevention and control of bleeding in patients with factor IX deficiency (hemophilia B).

Profilnine contains non-therapeutic levels of factor VII and is not indicated for use in the treatment of factor VII deficiency.

CONTRAINDICATIONS

None known.

WARNINGS

Transmissible Infectious Agents

Because Profilnine is made from human blood, it may carry a risk of transmitting infectious agents, e.g., viruses, the variant Creutzfeldt-Jakob disease (vCJD) agent and, theoretically, the Creutzfeldt-Jakob disease (CJD) agent.

Inhibitors

Patients can develop neutralizing antibodies (inhibitors) after treatment with Profilnine. Monitor patients for inhibitors, which should be quantified in Bethesda Units (BU) using appropriate laboratory testing.

Hypersensitivity

Hypersensitivity, including anaphylaxis, has been reported. Inform patients of the early symptoms and signs of hypersensitivity reaction, including hives, generalized urticaria, angioedema, chest tightness, dyspnea, wheezing, faintness, hypotension, tachycardia, and anaphylaxis.

Thrombosis

The use of factor IX complex concentrates has been associated with the development of thromboembolic complications. Patients at increased risk for thrombosis include those undergoing surgery, post surgery, with known liver disease, and with signs of fibrinolysis, thrombosis, or disseminated intravascular coagulation (DIC)⁶. When administering Profilnine to these high-risk patients, monitor for early signs of consumptive coagulopathy with appropriate laboratory testing. Only administer Profilnine to patients when the benefits outweigh the risks.

PRECAUTIONS

Vasomotor reactions may result from overly rapid administration. Do not exceed the recommended infusion rate of 10 mL/min.

Information for Patients

Advise patients to report to their physician any decrease in effectiveness of Factor IX treatment, as this can indicate development of inhibitors.

Hypersensitivity, including anaphylaxis, has been reported for factor IX complex concentrate products. Inform patients of the early symptoms and signs of hypersensitivity reaction, including hives, rash, swelling, chest tightness, shortness of breath, wheezing, faintness, decrease in blood pressure, and rapid heartbeat. Advise patients to discontinue use of the product and contact their physician and/or seek immediate emergency care if these symptoms occur.

Pregnancy Category C

Animal reproduction studies have not been conducted with Profilnine. It is also not known whether Profilnine can cause fetal harm when administered to a pregnant woman or can affect reproduction capacity. Only give Profilnine to a pregnant woman if clearly indicated.

Pediatric Use

Safety and effectiveness in pediatric patients have not been established.

Natural Rubber Latex Sensitivity

Certain components used in the packaging of this product contain natural rubber latex. In patients with sensitivity to natural rubber latex, use Profilnine only if needed.

ADVERSE REACTIONS

Adverse reactions with Profilnine may include headache, fever, chills, flushing, nausea, vomiting, tingling, lethargy, urticaria, and manifestations of allergic reactions.

The following adverse reactions have been identified during post-approval use of Profilnine: hypersensitivity reactions including shortness of breath, diaphoresis, and hypotension, as well as thrombosis including pulmonary embolism and deep vein thrombosis, disseminated intravascular coagulation, and inhibitor development. Because these reactions are reported voluntarily from a population of uncertain size, it is not always possible to reliably estimate their frequency or establish a causal relationship to drug exposure.

To report SUSPECTED ADVERSE REACTIONS, contact Grifols at 1-888-GRIFOLS (1-888-474-3657) or FDA at 1-800-FDA-1088 or www.fda.gov/medwatch.

DOSAGE AND ADMINISTRATION

Dose

Each vial of Profilnine is labeled with total units expressed as International Units (IU). According to the WHO International Standard, one unit approximates the activity in one mL of normal plasma. A 1% increase in factor IX (0.01 units) per unit administered per kg body weight can be expected¹. The amount of Profilnine required to establish hemostasis will vary with each patient and circumstance. Use the following formula and example as guides in determining the number of units to be administered:

$$\begin{array}{r} \text{Body weight (in kg)} \times \text{Desired increase in Plasma Factor IX (Percent)} \times 1 \text{ Units/kg} = \text{Number of Factor IX Units Required} \\ \text{Example: } 50 \text{ kg} \times 25 \text{ (\% increase)} \times 1 \text{ Units/kg} = 1,250 \text{ Units of factor IX} \end{array}$$

Due to variability among patients and their clinical condition, monitor the factor IX level of each patient frequently during replacement therapy.

Table 2 below provides treatment guidelines for hemorrhagic events and surgery in patients with factor IX deficiency.

Table 2: Treatment Guidelines

Type of Bleeding or Surgical Procedure	Factor IX Level Required, % of Normal (Dose)	Frequency of Doses	Duration of Therapy (Days)
Minor to Moderate Hemorrhages	20-30% (20-30 IU FIX/kg) until hemorrhage stops and healing has been achieved.	Every 16-24 hrs	Minor: 1-2 days Moderate: 2-7 days
Major Hemorrhages	30-50% (30-50 IU FIX/kg). Following this treatment period, maintain FIX levels at 20% (20 IU FIX/kg) until healing has been achieved.	Every 16-24 hrs	3-10 days
Surgery	Prior to surgery, 30-50% (30-50 IU FIX/kg). For dental extractions, bring FIX levels to 50% immediately prior to the procedure. Maintain FIX levels at 30-50% (30-50 IU FIX/kg) until healing has been achieved.	Every 16-24 hrs	7-10 days

* Unit refers to International Unit in the labeling of Profilnine.

Dosing requirements and frequency of dosing are calculated on the basis of an initial response of 1% FIX increase achieved per IU of FIX infused per kg body weight and an average half-life for FIX of 24 hours. If dosing studies reveal that a particular patient exhibits a lower response, monitor blood levels and adjust the dose accordingly.

Reconstitution

Use Aseptic Technique

1. Ensure that concentrate (Profilnine) and diluent (Sterile Water for Injection, USP) are at room temperature (but not above 37 °C) before reconstitution.
2. Remove the plastic flip off cap from the diluent vial.
3. Gently swab the exposed stopper surface with a cleansing agent such as alcohol. Avoid leaving any excess cleansing agent on the stopper.
4. Open the Mix2Vial® package by peeling away the lid (Figure 1). Leave the Mix2Vial in the clear outer packaging.
5. Place the diluent vial upright on an even surface, hold the vial tightly, and pick up the Mix2Vial in its clear outer packaging. While holding the diluent vial securely, push the **blue** end of the Mix2Vial vertically down through the diluent vial stopper (Figure 2).
6. While holding onto the diluent vial, carefully remove the clear outer packaging from the Mix2Vial set, ensuring the Mix2Vial remains attached to the diluent vial (Figure 3).
7. Place the product vial upright on an even surface, invert the diluent vial with the Mix2Vial attached.
8. While holding the product vial securely on a flat surface, push the **clear** end of the Mix2Vial set **vertically** down through the product vial stopper (Figure 4). The diluent will automatically transfer out of its vial into the product vial.

NOTE: If the Mix2Vial is connected at an angle, the vacuum may be released from the product vial and the diluent will not transfer into the product vial.

9. With the diluent and product vials still attached to the Mix2Vial, gently swirl the product vial to ensure the product is fully dissolved (Figure 5). Reconstitution requires less than 10 minutes. Do not shake the vial.
10. Disconnect the Mix2Vial into two separate pieces (Figure 6) by holding each vial adapter and twisting counterclockwise. After separating, discard the diluent vial with the **blue** end of the Mix2Vial.
11. Draw air into an empty, sterile syringe. Keeping the product vial upright with the **clear** end of the Mix2Vial attached, screw the disposable syringe onto the luer lock portion of the Mix2Vial device by pressing and twisting clockwise. Inject air into the product vial.
12. While keeping the syringe plunger depressed, invert the system upside down and draw the reconstituted product into the syringe by pulling the plunger back slowly (Figure 7).
13. When the reconstituted product has been transferred into the syringe, firmly hold the barrel of the syringe and the clear vial adapter (keeping the syringe plunger facing down) and unscrew the syringe from the Mix2Vial (Figure 8). Hold the syringe upright and push the plunger until no air is left in the syringe. Attach the syringe to a venipuncture set.

NOTE: If the same patient is to receive more than one vial of concentrate, the contents of two vials may be drawn into the same syringe through a separate unused Mix2Vial set before attaching to the venipuncture set.

14. After reconstitution, inspect parenteral drug products visually for particulate matter and discoloration prior to administration, whenever solution and container permit. When reconstitution procedure is strictly followed, a few small particles may occasionally remain. The Mix2Vial set will remove particles and the labeled potency will not be reduced.
15. Do not refrigerate after reconstitution. The reconstituted product is stable for 3 hours at room temperature; use as soon as possible within 3 hours after reconstitution.

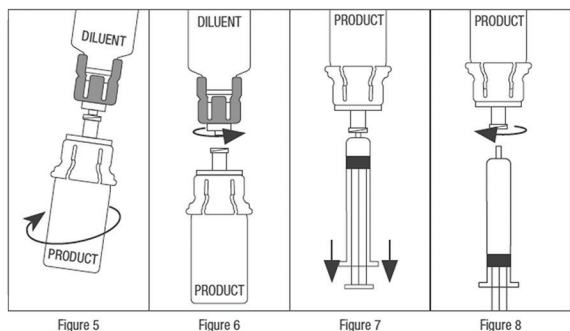
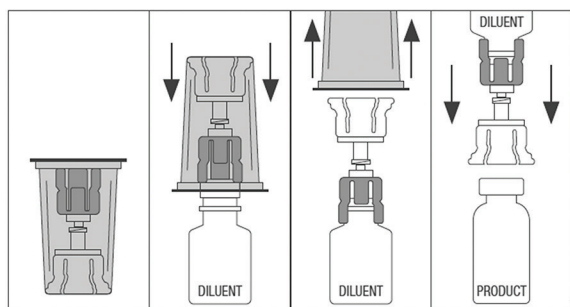

Administration

For intravenous administration only

- Inspect the final solution visually for particulate matter and discoloration prior to administration.
- Administer the prepared drug at room temperature within three hours after reconstitution. Prompt administration is recommended to avoid ill effects of any inadvertent bacterial contamination occurring during reconstitution.
- Administer by intravenous injection (plastic disposable syringe only) or infusion at a rate not exceeding 10 mL/minute.
- Discard any unused Profilnine vial contents. Discard administration equipment into the appropriate safety container after single use. Do not resterilize components. Do not reuse components.

HOW SUPPLIED

Profilnine is supplied in sterile lyophilized form in single-dose vials accompanied by a suitable volume of diluent (Sterile Water for Injection, USP), according to factor IX potency. Each vial is labeled with the factor IX potency expressed in International Units which is referenced to the WHO International Standard. Profilnine is packaged with a Mix2Vial filter transfer set for use in administration.

The product is available in several potencies, with carton and vial label color coded based upon assay as follows:

Potency	Carton NDC	Assay Color Code
500 units FIX/5 mL	68516-3201-1 or 68516-3207-1	500 units FIX Range—blue
1000 units FIX/10 mL	68516-3202-2 or 68516-3208-2	1000 units FIX Range—red
1500 units FIX/10 mL	68516-3203-2 or 68516-3209-2	1500 units FIX Range—black

The diluent vial stopper contains natural rubber latex. All other components of the kit are not made with natural rubber latex.

STORAGE

Profilnine is stable for three years, up to the expiration date printed on its label, provided that the storage temperature does not exceed 25 °C (77 °F). Do not freeze.

Rx only

REFERENCES

1. Menache, D., Roberts, H.R. Summary report and recommendations of the task force members and consultants. *Thromb Diath Haemorrh* 33:645-647, 1975.
2. Kingdon, H.S., Lundblad, R.L., Veltkamp, J.J., Aronson, D.L. Potentially thrombogenic materials in Factor IX Concentrates. *Thromb Diath Haemorrh* 33:617-631, 1975.
3. Burnouf T, Radosevich M. Nanofiltration of plasma-derived biopharmaceutical products. *Haemophilia: the official journal of the World Federation of Hemophilia*. 2003;9:24-37.
4. Dichtelmüller HO, Biesert L, Fabbri F, Gajardo R, Gröner A, von Hoegen I, Jorquera JI, Kempf C, Kreil TR, Pifat D, Osheroff W, Poelsler G. Robustness of solvent/detergent treatment of plasma derivatives: a data collection from Plasma Protein Therapeutics Association member companies. *Transfusion* 49:1931-1943, 2009.
5. Sorensen, B., Spahn, D.R., Innerhofer, P., Spannagl, M., Rossaint, R. Clinical review: prothrombin complex concentrates—evaluation of safety and thrombogenicity. *Critical Care* 15: 201-209, 2011.

Manufactured by:
Grifols Biologicals Inc.
 5555 Valley Boulevard
 Los Angeles, CA 90032, U.S.A.
 U.S. License No. 1694
 DATE OF REVISION: March 2017